



Model: XPD721W

700 TVL Vandal Resistant Day/Night Dome

Before you begin

- Please unpack the box carefully and identify that all the parts are present.

The camera is suitable for indoor or outdoor use. Please bear in mind the following points when choosing a mounting position.

- The camera must be positioned so that it will not point directly into the sun (sunrise and sunset) or any bright light, as this may cause damage to the camera.
- Do not cut the camera cables, this will void the warranty.
- Make sure you use only the recommended power supply. Damage caused to the camera by incorrect voltage or wiring is not covered by the warranty.

Model:

XPD721W

700 TVL Vandal Resistant Day/Night Dome

Thank you for purchasing this Xvision camera. Before operating this product, please read this instruction manual carefully.

1. Safety Precautions



CAUTION

RISK OF ELECTRIC SHOCK.
DO NOT OPEN!



CAUTION: TO REDUCE THE RISK OF ELECTRIC SHOCK, DO NOT OPEN COVERS UNLESS MAKING LENS ADJUSTMENTS. NO USER SERVICEABLE PARTS INSIDE. REFER SERVICING TO QUALIFIED SERVICE PERSONNEL.

2

- Use with a 12V DC regulated power supply.
- To prevent fire or electrical shock, industry standard wiring should be used for the 12V DC input terminal.
- Be sure to connect each lead to the appropriate terminal. The incorrect connection may cause malfunction and/or damage to the camera.
- Do not attempt to point the camera at the sun or other extremely bright objects. It can cause image smearing whether the camera is powered on or not and can lead to the damage of the CCD (Charge Coupled Device).
- When camera is installed next to equipment, such as wireless communication device, that emits a strong electromagnetic field, some irregularity such as noise on the monitor screen may occur.
- Be sure to use a ceiling board that has enough strength to support this camera.
- Do not pull the camera cable, this may cause it to disconnect from the internal camera.
- Do not touch the inside of camera even if something is wrong.
- Before installation, be sure to disconnect the power supply first, check the ground connection, and then install the camera.
- Operating temperature: $-10^{\circ} \sim +50^{\circ}\text{C}$
- Storage temperature: $-20^{\circ} \sim +60^{\circ}\text{C}$
- Be sure to use the screws supplied with the camera for installation.

2. Product Description

The XPD721W dome camera is designed for high risk applications and is able to withstand a blow from a 120 pound sledgehammer. It offers very high resolution images of 600 TVL in Colour mode and 700 TVL in B/W mode, with a low lux sensitivity of 0.0003 lux. It features Dynamic Night View, Number Plate Recognition, Wide Dynamic Range, Smart DNR for disk saving and an Auto Iris Varifocal Lens with 36x Optical Zoom. It is designed for internal or external use and can be wall or ceiling mounted.

3. Features

- 700 TVL resolution images in B/W mode and 600 TVL in Colour.
- Sony 1/3" Next Generation CCD Image Sensor with Xvision DSP.
- 2.8 to 11.0mm Varifocal Auto Iris Lens for 26 to 92° viewing angle for super sharp images and easy selection of the optimum viewing angle during installation.
- Dynamic Night View technology provides clear images without the need for IR LEDs down to 0.0003 lux, this is achieved by using Field Integration. Please note due to the way in which field integration works, whilst it is in operation the frame per second will be reduced. The darker the scene, the lower the frame per second.
- Smart DNR (3D Digital Noise Reduction) reduces the noise on the image when viewing in low lux environments (like at night). This reduces the size of the image when being recorded by a DVR, resulting in a saving of disk space.
- D-WDR (Digital Wide Dynamic Range) feature allows the camera to display balanced pictures even when the scene being watched has bright spots or various light levels and back light conditions.
- Number Plate Recognition using advanced Highlight Suppression Technology.
- Manual pan/tilt mechanism with 3-Axis Rotation.
- Designed for Wall or Ceiling Mounting, suitable for Internal or External use.

4. Contents

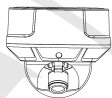

XP721W Camera

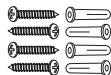

Screws & Wall Plugs



Opening Tool



Allen Key

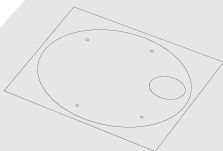

Template



Wall Plugs & Screws

4

Use of Accessories:

1. OPENING TOOL: Needed for opening up the pipe holes during cabling.
2. ALLEN KEY: For body cover and camera base assembly.
3. TEMPLATE: A drilling guide for use during installation.
4. RUBBER PAD: A waterproof pad for use at the base of the camera during installation.

5. Product Assembly

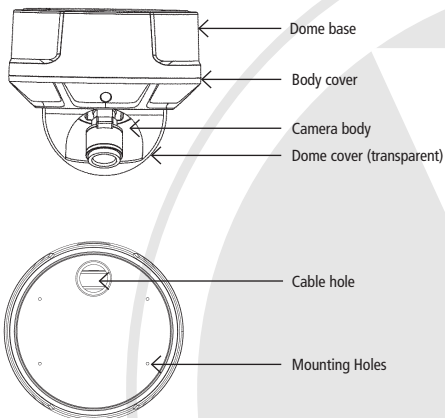

5

Handling the camera:

1. Never attempt to disassemble or modify the camera.
2. If an abnormality should occur, immediately turn off the power and consult your dealer.

Cover Removal and Attachment

1. To remove the body cover, disassemble it with the Allen Key provided in the accessory set. (Rotating clockwise will close it and anti-clockwise will release it).
2. To attach it, align the edge of body cover to the groove on the Dome base. Turn the dome until the lens points to the opening window, and then screw it tightly into place.

6. Installation

FIX THE DOME BASE

1. Attach the provided template to where you want to install the camera and drill the holes in the place where the camera is to be installed, then run the power and video cables through the hole.
2. Disassemble the dome base from the dome base.
3. Fix the Dome base on the wall or the ceiling using the wall plugs and screws supplied.

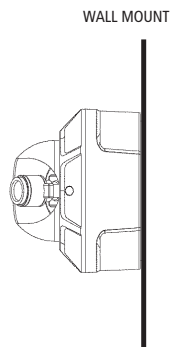
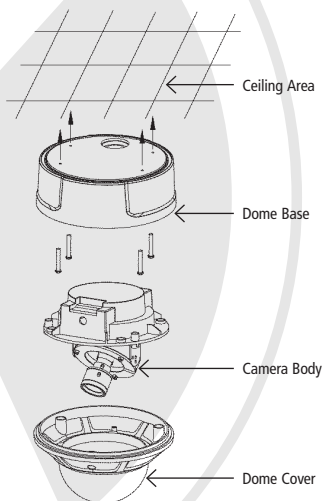

ADJUST THE CAMERA LENS

Camera body moves in three ways. It can be panned, tilted and rotated.

4. Adjust the direction so that the lens is pointing at the target.
5. Use the lever to adjust the view angle and focus.

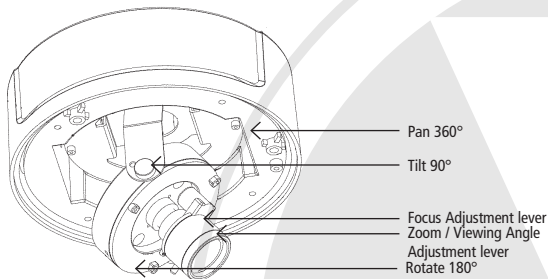

ATTACH THE BODY COVER

6. Turn the dome cover to adjust the lens to the opening window.

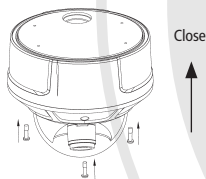

7

CONNECT THE POWER & VIDEO CABLES

7. Connect the video output to the monitor or other video device through a 75 Ohms type coaxial cable.
8. Connect the power source, insert the AC plug into the AC socket and the DC plug into the DC Jack (+12V DC in jack centre).



Once the picture appears on the monitor, make the final Zoom and Focal adjustments if required.

7. Camera OSD Control

Various camera settings can be adjusted using the OSD buttons located in the dome. Press the Set button to enter the OSD Menu.

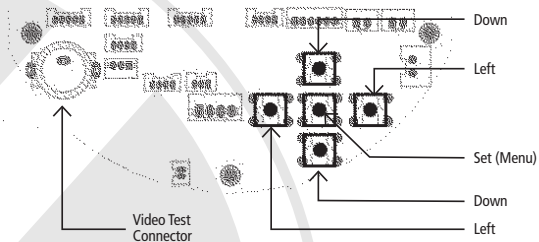

OSD Button Control Actions

Press this Control	For this Action
UP, DOWN	Select between items in a list
LEFT, RIGHT	Select a menu item to change its setting
SET (MENU)	Access a sub menu

8. OSD Menu Structure

SETUP MENU

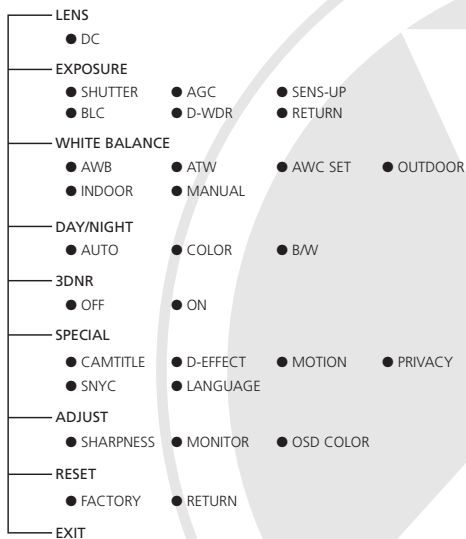

9. SETUP Menu Functions

1. LENS

<Option : DC>

This should be left on the default DC setting.

2. EXPOSURE

<Option : SHUTTER / AGC / SENS-UP / BLC / D-WDR / RETURN>

- **SHUTTER:** Adjusts shutter settings <AUTO / FLK / MANUAL>
 - **AUTO** - Adjusts shutter settings to control the brightness level on screen.
 - **FLK (Flickerless mode)** - Reduces on-screen flickering. FLK is the only option available when the camera lens is set to DC mode.
 - **MANUAL** - Allows you to adjust the shutter speed from 1/50~1/100,000 (PAL).
- **BRIGHTNESS:** Adjusts brightness settings
- **AGC:** Automatic Gain Control <HIGH / MIDDLE / LOW / OFF>
For better performance in low light conditions the AGC can be increased. This has the effect of making the picture brighter (however it may also add more noise to the picture as it is amplifying all aspects of the video signal).
- **SENS-UP (DYNAMIC NIGHT VIEW):** <AUTO / OFF>
To get a clear image under night or low lighting levels by providing higher sensitivity in low light conditions. NOTE only adjustable if SHUTTER setting is set to 'AUTO' or '1/60'
 - **OFF** - Deactivate SENS-UP feature.
 - **AUTO** - In low light or at night time, select this feature. Enter the submenu to select maximum low shutter value from X2 to X256 (use the X256 setting for the lowest lux level response of the camera).
We recommend keeping the value in the x2 to x64 range to limit ghosting effect.
- **BLC:** Back Light Compensation <OFF / BLC / HSBLCL>
The BLC function makes objects in front of a bright scene (such as a window on a bright sunny day) clearer to see by increasing their brightness and making the background darker.
 - **OFF** - Deactivate BLC feature (default setting).
 - **BLC** - Enter the BLC submenu to select an area in the scene which requires enhancing. Set the GAIN setting to the level of enhancement required (select either Low, Middle or High).

9. SETUP Menu Functions continued

- **HSBLC (Highlight Suppress BLC for Numberplate Recognition)** - Select this feature to select masking of bright areas in the image, such as when viewing number plates when car headlights are on. Enter the HSBLC submenu to select an area in the scene which requires masking. Change the LEVEL value to set level of masking and change MODE to set whether to mask all day long or during low light conditions only.
- **D-WDR: Wide Dynamic Range** <OFF / INDOOR / OUTDOOR>
Wide Dynamic Range allows the camera to display balanced pictures even when the scene being watched has bright spots or various light level and back light conditions. Select INDOOR or OUTDOOR mode to activate this feature depending on the environment the camera is installed in.
 - **OFF** - Deactivate D-WDR feature (default setting).
 - **INDOOR** - Preferred setting when camera is installed indoors. Default settings are LOW-6 and HIGH-9
 - **OUTDOOR** - Preferred setting when camera is installed outdoors. Default settings are LOW-11 and HIGH-11

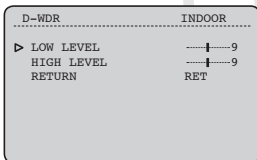

- **RETURN:** Select to return to Main Menu.

9. SETUP Menu Functions continued

3. WHITE BALANCE (WHITE BALANCE MENU)

<Option : AWB / ATW / AWC-SET / OUTDOOR / INDOOR / MANUAL >

- **AWB:** Automatic White Balance (default setting). This feature automatically adjusts the colour temperature of the camera image to match the type of light available, so that white and other colours appear as natural as possible.
- **ATW:** Auto Tracking White Balance. Use this mode when the colour temperature is between 1800°k~10,500°k
- **AWC-SET:** Find the optimal setting for the current luminance environment in this mode. Set the point the camera towards a sheet of white paper and press the SET button. If the environment changes, re-adjust it.
- **OUTDOOR:** Select this when the colour temperature is between 1,800°K and 10,500°K. (sodium light)
- **INDOOR:** Select this when the colour temperature is between 4,500°K and 8,500°K.
- **MANUAL:** To fine-tune the White Balance manually, set White Balance first by using the ATW or AWB mode. After that switch to Manual mode, fine-tune the White Balance by adjusting the Red Gain and Blue Gain between 0~100.

12

4. DAY/NIGHT

<Option : AUTO / COLOR / B/W >

- **AUTO:** Sets the display to automatically switch to colour in a normal environment, and to B/W when illumination is low. To set up the switching time or speed for AUTO mode, press the joystick. Then set the Delay in seconds for the 'Day to Night' and the 'Night to Day' transitions.
- **COLOR :** Sets the display to always show a colour picture.
- **B/W:** Sets the display to always show a B/W picture.

5. 3DNR - 3D DIGITAL NOISE REDUCTION

<Option : ON / OFF>

Select this function to reduce the noise on the image when viewing in low lux areas (like at night), this reduces the size of the image when being recorded by a DVR, resulting in a saving of disk space. The 3D function reduces the noise on all 3 dimensions of an object, resulting in a better image than is possible with standard Digital Noise Reduction.

Noise levels can be very subtle, and may not be always noticeable on adjusting. Remember that the higher the level set, the more the noise level will be reduced, however this can have a softening effect on the image.

- **ON:** Activate 3DNR by selecting the desired 3DNR level (0 to 100; default value is 60)
- **OFF:** Deactivate 3DNR Mode.

9. SETUP Menu Functions continued

6. SPECIAL MENU

6.1 CAM TITLE <Option : ON / OFF>

Use the feature to display a title on the monitor.



- **ON:** Move the the joystick left/right/up/down to select a letter/number/symbol and press joystick to confirm selection. Repeat steps until camera title is completed and select 'POS' to select on-screen location for title and 'END' to save title. You can enter up to a maximum of 15 characters.
- **OFF:** Deactivate CAM TITLE. No title will be appeared on the monitor.

If you select CLR and press the joystick, all the letters will be deleted. To edit a letter, change the cursor to the bottom left arrow and press the joystick. Move the cursor over the letter to be edited, move the cursor to the letter to be inserted and then press the joystick.

13

6.2 D-EFFECT <Option : FREEZE / MIRROR / D-ZOOM / NEG.IMAGE / RETURN>

Use Digital Effect for specific effects.

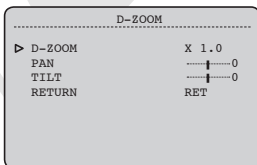
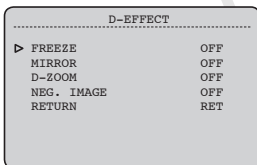

- **FREEZE:** Hold the camera image displayed on screen.
- **MIRROR:** <MIRROR / V-FLIP / ROTATE / OFF > Select the required setting to mirror the picture horizontally, vertically or to rotate it (mirror and flip the image). Default is OFF.
- **D-ZOOM** To enable up to 32x Digital Zoom. Set your desirable Zoom ratio & position using the Pan and Tilt settings (selectable range is between -100 and 100).
- **NEG.IMAGE:** Changes the camera image to display in 'negative' colours.

9. SETUP Menu Functions continued

6.3 MOTION

<Option : ON / OFF>

This function will transmit an alert signal when it detects motion on screen.

MOTION	
▶ AREA SELECT	AREA 1
AREA DISPLAY	ON
LEFT/RIGHT	— — 8
WIDTH	— — 32
TOP/BOTTOM	— — 4
HEIGHT	— — 24
SENSITIVITY	— — 40
MOTION VIEW	OFF
RETURN	RET

- **ON:** Activate Motion Detection mode. Select the motion detection area where you want by using the Joystick control. Up to 4 areas can be set.
 - **AREA SELECT:** Select motion detection area number (AREA 1-4). The area selected will flash on and off visually.
 - **AREA DISPLAY:** Turns the selected motion detection area ON or OFF. Pressing the joystick when ON will change the display to set the position and the size of the area. Moving the joystick will change the setting, pressing joystick will set the changes. After you have set both position and size using the scaled bars you can RET or set another area.
 - **SENSITIVITY:** Adjust sensitivity for selected motion detection area (0-40).
 - **MOTION VIEW:** Turn Motion Detection view ON or OFF. When turned on, upon the detection of motion, green dots will appear to indicate the area in which the motion is taking place.
- **OFF:** Deactivate Motion Detection mode.

14

6.4 PRIVACY

<Option : ON / OFF>

This function will mask up to 8 areas so that it is not displayed on the monitor.

PRIVACY	
▶ AREA SELECT	AREA 1
AREA DISPLAY	ON
LEFT/RIGHT	— — 8
WIDTH	— — 16
TOP/BOTTOM	— — 8
HEIGHT	— — 16
COLOR	— — 0
RETURN	RET

continued

9. SETUP Menu Functions continued

- **ON:** Activate Privacy. Select the areas to be masked by using the Joystick control.
AREA SELECT: Select privacy area number. (AREA 1-8). The area selected will flash on and off visually.
 - **AREA DISPLAY:** Turns selected privacy area ON or OFF. Pressing joystick when ON will change the display to set the position and the size of the area. Moving the joystick will change the setting, pressing joystick will set the changes. After you have set both position and size using the scaled bars you can RET or set another area.
 - **COLOR:** <0 to 15> Sets the colour of the selected privacy area.
- **OFF:** Deactivate Privacy mode.

6.5 SYNC <Option : INTERNAL / LINE LOCK >

Two SYNCHRONIZATION modes are available, Internal / Line Lock.

6.6 LANGUAGE <Option : ENG / KOK / JPN / CHN / CHN2 / RUS >

Select the language the OSD Menu will be displayed in.

15

7. ADJUST <Option : SHARPNESS / MONITOR / OSD COLOR / RETURN >

Adjust Sharpness, OSD Colour levels on the camera image.

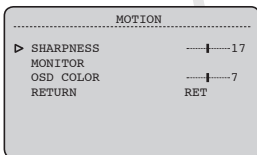

- **SHARPNESS:** Select the edge sharpness, 0 (soft image) to 31 (sharp). Default is 12.
- **MONITOR:** <CRT/LCD/User> For direct monitor connection only. Default is CRT.
- **OSD COLOR:** <1/2/3> Adjust the text colour level on the OSD menu. Default is 3.

8. RESET

Resets all settings to Factory Default.

9. EXIT (SAVE)

Select to save OSD Menu settings and EXIT the Setup Menu.

Specifications

Model: XPD721W

Picture Type:	Day/Night (B/W & Colour)
Image Sensor:	Sony 1/3" Next Generation CCD
DSP:	Xvision
Resolution:	600 TVL (Colour mode) 700 TVL (B/W mode)
Lens Viewing Angle:	26 to 92°
Digital Zoom:	x32
Infra Red Night Vision:	No
Minimum Illumination:	0.0003 Lux
Audio:	No
Operating Voltage:	12V DC 150mA
Suggested Power Supply:	12V DC 300mA
Mounting:	Wall or Ceiling
Weatherproofing:	Yes
Dimensions (WxHxD):	150 x 130 x 150mm

16

TECHNICAL SUPPORT:

For Technical Support for any Xvision product please contact your local distributor.

LIMITED WARRANTY:

This product is supplied with a 3 Year warranty. The Warranty excludes products that have been misused, (including accidental damage) and damage caused by normal wear and tear. In the unlikely event that you encounter a problem with this product, it should be returned to the place of purchase.

Manufactured exclusively for Xvision - www.x-vision.co.uk

**Head Office**

Xvision Group (UK)
Unit 2, Valley Point, Beddington Farm Road,
Croydon, Surrey CR0 4WP
E: sales@x-vision.co.uk

Far East Office

Kyoung Am Building,
157-27 Samsung-dong
Kangnam-ku, 135 090 Seoul, Korea
E: globalsales@x-vision.co.uk